

SPAR Offshore Platform Simulation Using ANSA & META

Offshore platforms are large structures designed to withstand extreme weather conditions and have a lifespan of at least 40 years. Million dollars have to be invested for research, materials and equipment for their construction. Any mistake in design or in system operations could lead to dramatic results, with effects not only on the platform but on the environment and the personnel as well. Computational analysis and simulations of several load-cases with FE models is a powerful tool for engineers in the offshore industry to help in reducing such risks.

SUMMARY

A complete model of a SPAR offshore platform was created in ANSA with the help of the related Topology functions. The transformation tool was also used to take advantage of the cylindrical symmetry of the model and speed up the whole process. The whole model consists of shell elements with a variable element length according to the area of interest thus creating a rather fine meshing for a global model analysis. The model is also structurally prepared for further simplification by replacing the longitudinal stiffeners with beam elements.

::SPAR-PLATFORM::SOL1: SUBCASE 1

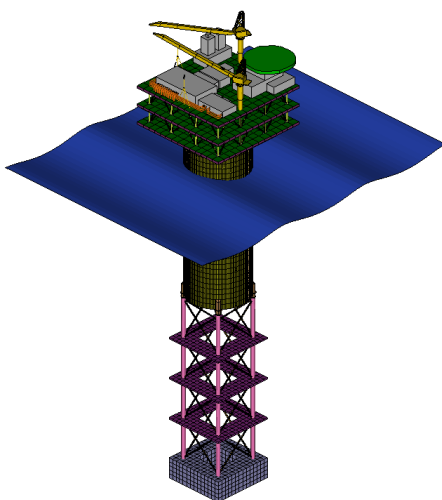

Once the geometrical model is finished it is ready to be set up for any specific load-case. As a first analysis, still water loading conditions were applied for a static solution in NASTRAN (sol 101) with the platform fully loaded. Masses were distributed all over the hull, the deck and the tanks of the platform, to simulate the equipment payload, and the ballast production and storage tanks weight when fully loaded. Also, mooring forces were applied to the specified hull points as well as gravity acceleration. Finally buoyancy was applied as hydrostatic pressure in the elements bellow waterline varying linearly with water depth. Additionally some parts like the soft tank and the heave plates were modeled as rigid, as there is no interest in taking results for these parts at this point.



The platform is now at rest in a state of equilibrium between its own weight, the auxiliary payload, and the resultant buoyancy. However in order to ideally simulate the equilibrium state, the method of inertia relief was used setting the corresponding parameter in NASTRAN. Finally the results were analyzed with the help of META post processor.

SPAR GEOMETRY & WEIGHT DISTRIBUTION

Some characteristic geometrical data of the model as well as weight distribution data are presented in the table below.

Hull diameter (m)	30
Hull Height (m)	80
Total Height (m)	196
Depth (m)	157
Lightweight Tonnage	7000
Deadweight Tonnage	45000
Type of platform	SPAR

The main parts that constitute the hull are the internal and external walls, the basic flats, the ring frames, and the compartment walls. Also every shell surface is supported with L shape longitudinal stiffeners. To complete the platform, the soft tank with its base and the deck are also modeled.

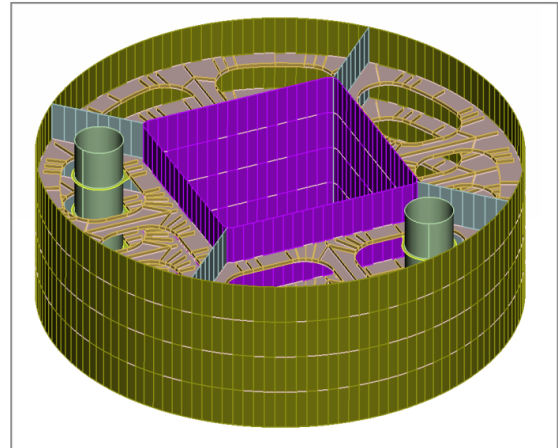

The weight distribution will be more analytically presented in the LOADCASE section.

MESH

The element length varies from 60 to 600 mm depending on the level of interest and detail of the surfaces. Some data regarding meshing and FE model are presented below.

Element length (m)	0.06 to 0.6
Total number of shells	585134
Total quads	566194
Total trias	18940
Quality Criteria	
Skewness (NASTRAN)	30
Aspect ratio (NASTRAN)	5

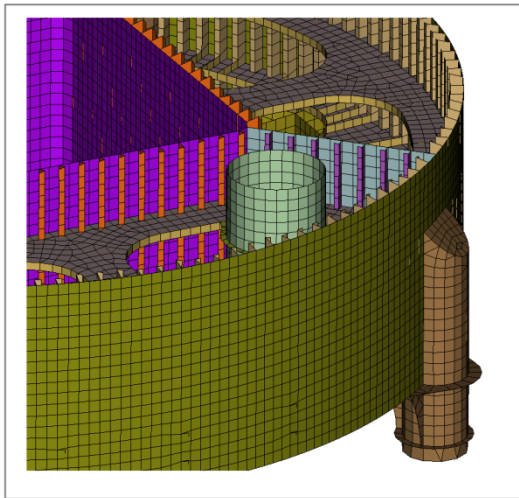

LOADCASE

Net weight of the structure is considered to be 7000 tonnes:

- 3500 tonnes for the Hull,
- 1700 tonnes for the deck and
- 1800 tonnes for the soft tank.

Masses were distributed all over the platform to simulate the fully loaded state.

- To the soft tank, 7300 tonnes were added.
- For the topsides payload (facilities, equipment), 9900 tonnes were added to the decks.
-

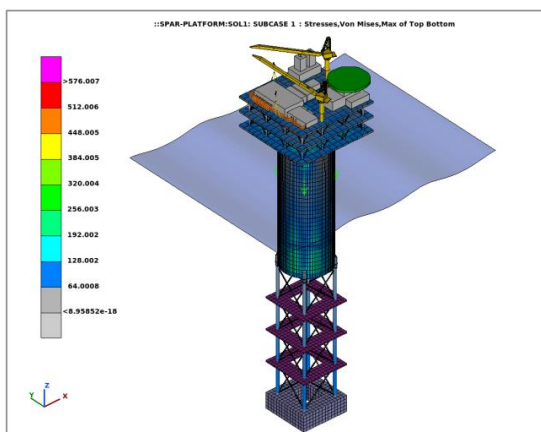

For the hull equipment and fluids of the

tanks

- 5000 tonnes were added to the upper part of the Hull
- 7000 tonnes were added to the lower part of the Hull

Mooring forces ($2 \cdot 10^7$ N each) were applied to four anchor points.

Also, gravity was applied to the whole model with an acceleration factor of 9810 mm/s^2 .

Having defined the total weight of the structure and by using a simplified model to describe the outer surface only, it is possible to find the waterline using the ANSA Tank Tool by calculating the volume that the platform occupies underwater. The sea level is estimated 64.67 m above Hull base.

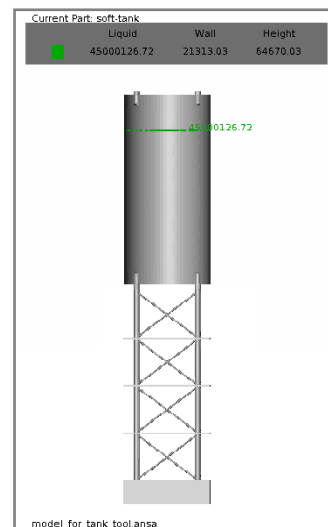

As a last step, buoyancy pressure is applied to every element below waterline, varying according to water depth. The results can be visualized through an element pressure graph. The resultant buoyancy force is calculated at about $41.86 \cdot 10^7$ N.

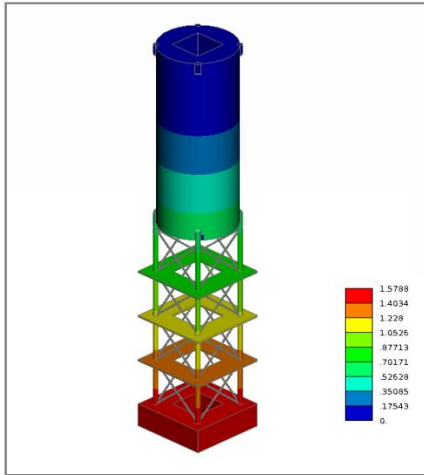

Setting the inertia relief parameter in NASTRAN to -2 there is no need of SPC use in the model and the platform remains unrestrained. NASTRAN will counteract any remaining resultant force or moment by applying inertial forces induced by an acceleration field. In this way, it is possible to have a static solution.

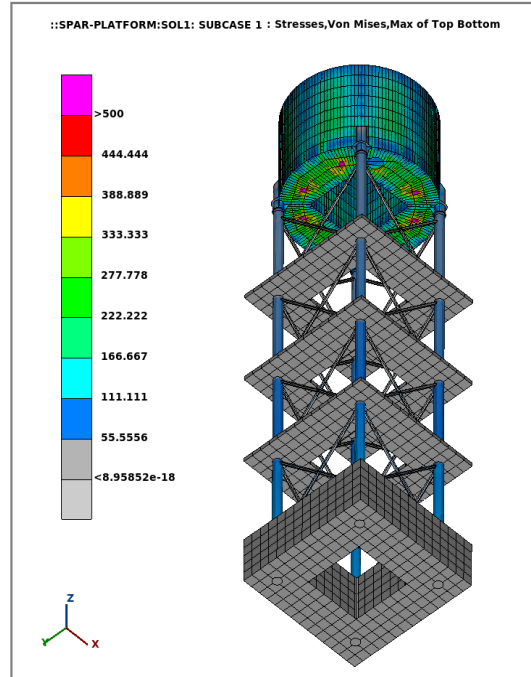

CPU time needed for a static solution is estimated to be 40 min using 6 cores.

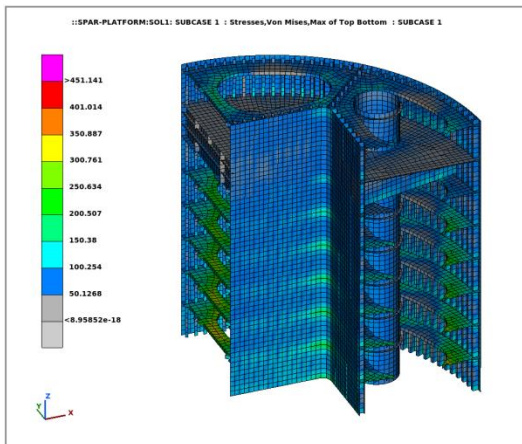

Strains, stresses and displacements are examined then in META. Critical areas with high stress values can be identified and further analysis can be done for every case. Some results are presented below.

For more information, contact: ansa@beta-cae.com