

**BETA**  
SIMULATION SOLUTIONS

**ANSA & META**  
for Battery  
Electromagnetic Simulations

**Compression Load**

**Electromagnetic  
Components**

**Thermal**

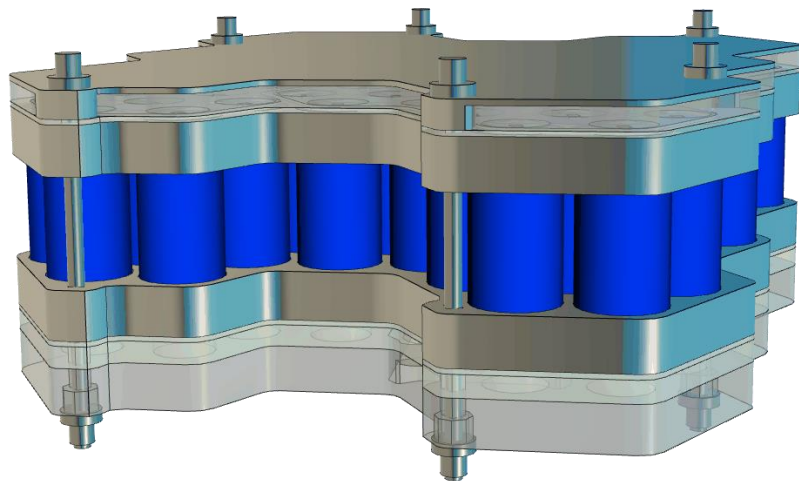

**Coupled simulation in  
time domain**

Why do we need Electromagnetic Simulations?

What are the challenges arising?

How can this topic be expanded?

Rapidly increasing demand in electromagnetics

Battery Simulations in Electric Vehicles

Tight Control of: Temperature, Voltage, Stresses

Lithium-Ion Battery Technology

## Battery Circuit

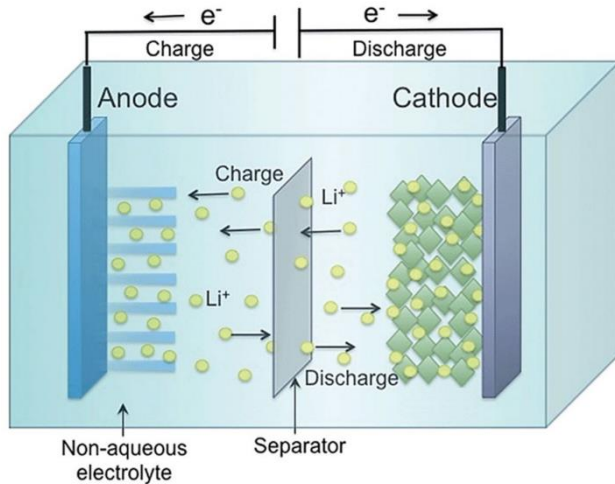

## Randles Circuit

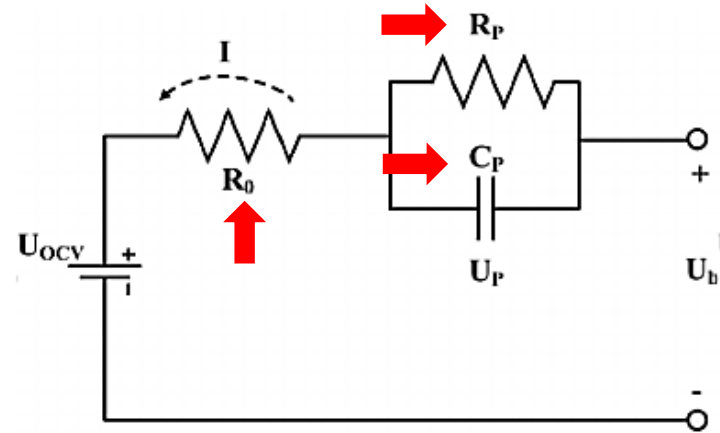

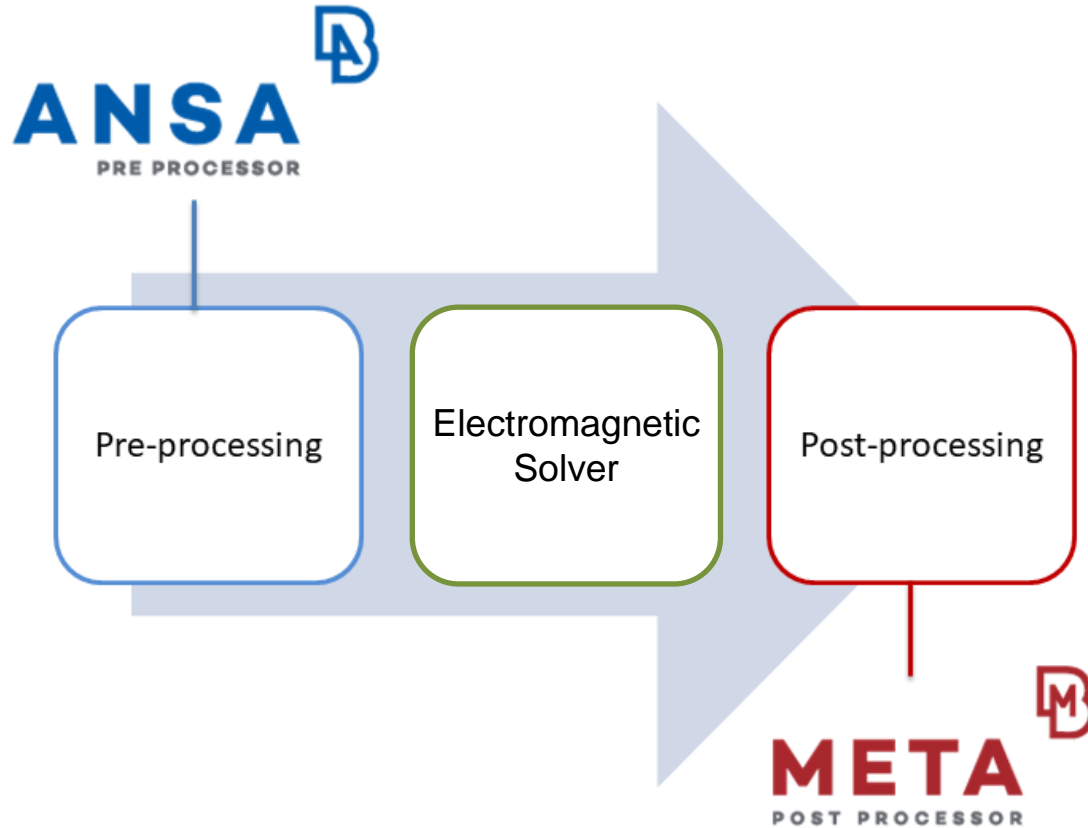

21700 Cylindrical battery



Square battery

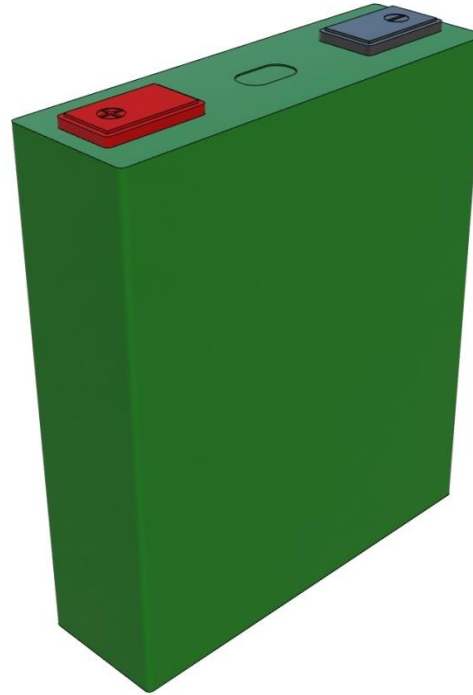

Import CAD file



Defeaturing

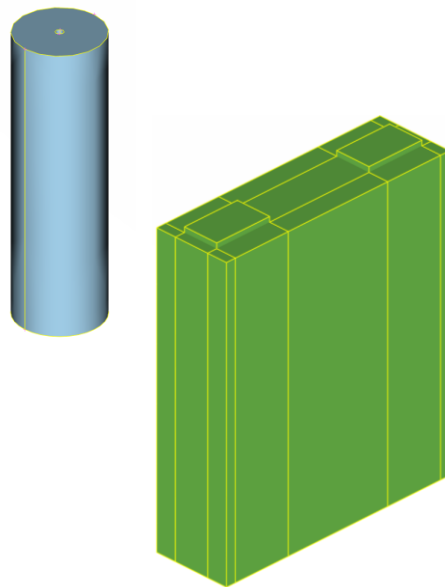

Finite Volume Mesh

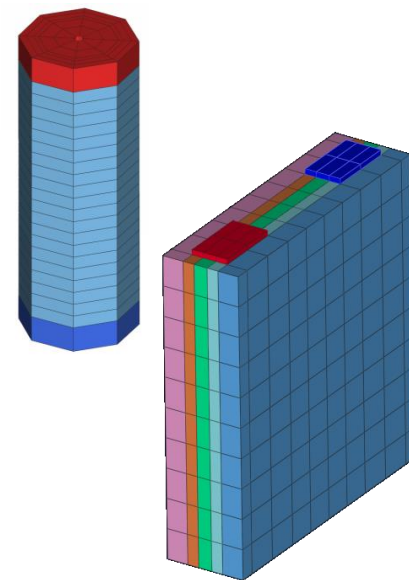



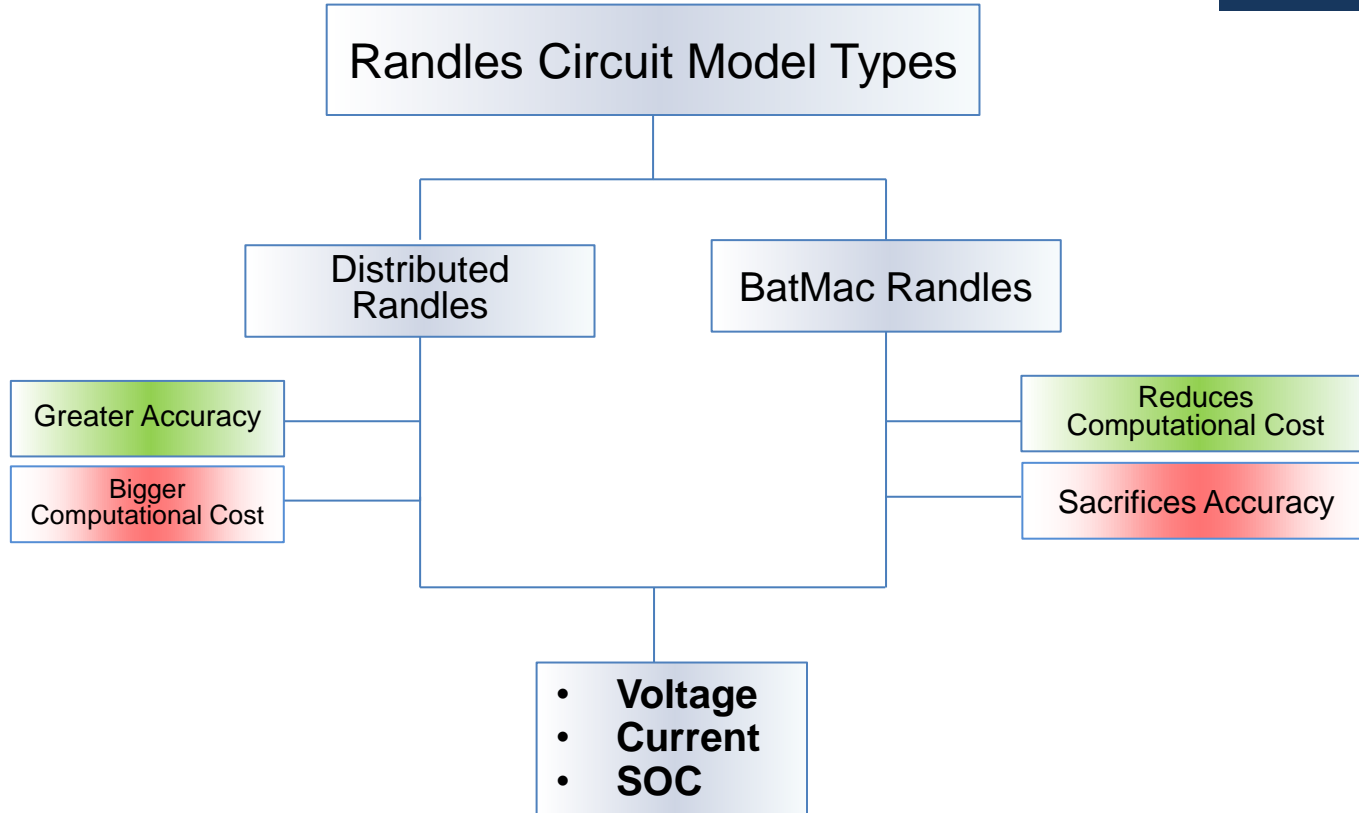

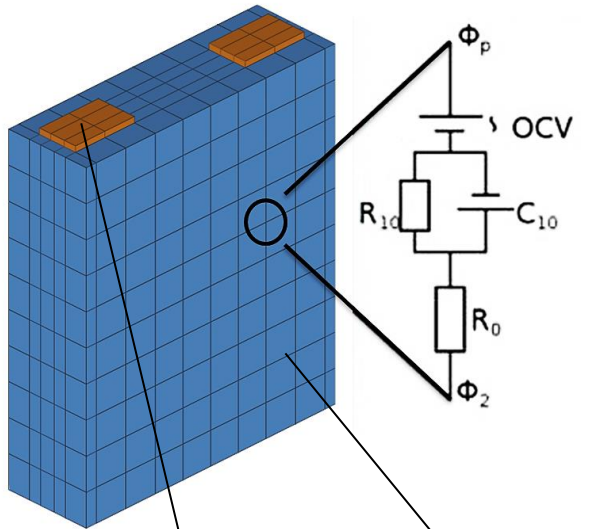

EM\_MAT\_006

EM\_MAT\_001

Two-material setup

Electromagnetic properties definition

Open Circuit Voltage curve definition

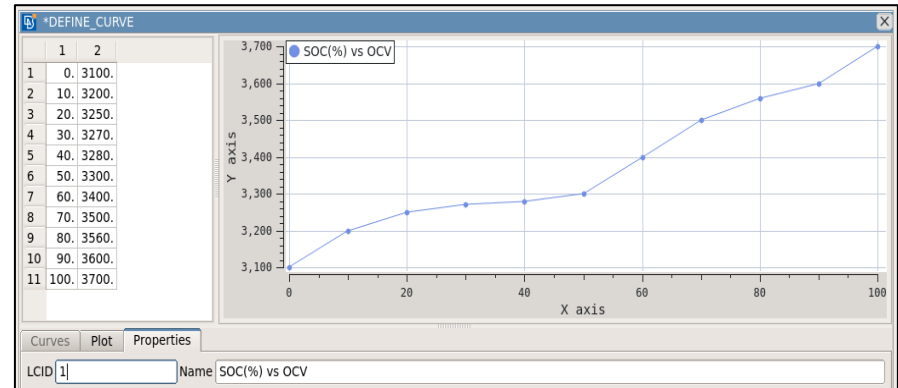

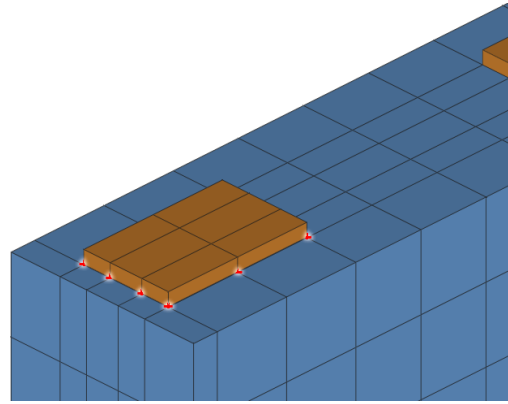
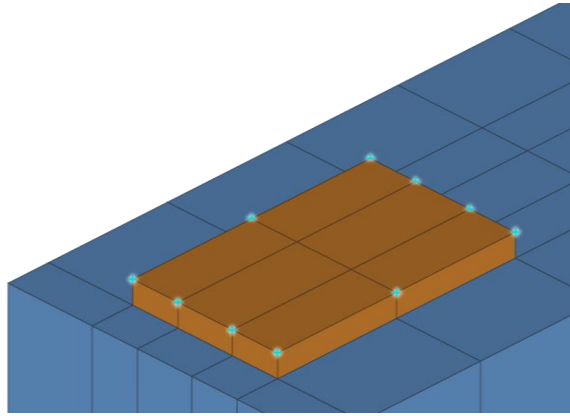

Isopotential Definition

Isopotential Connection Definition

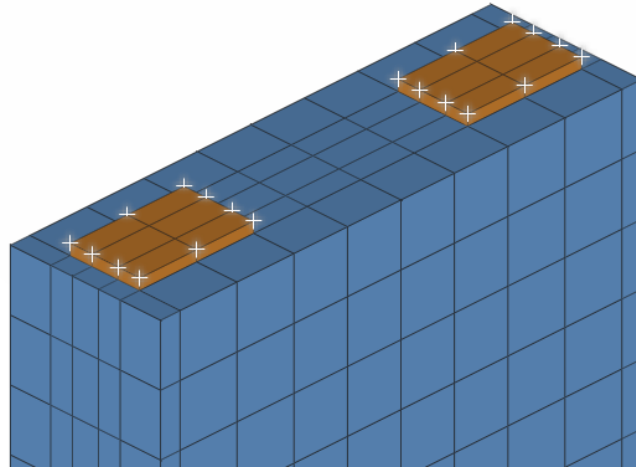

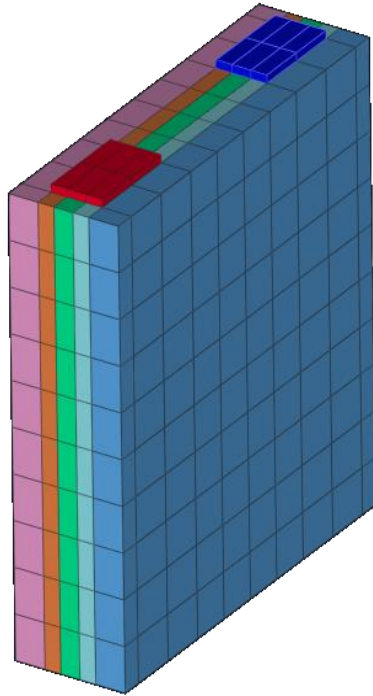

Negative Current Collector

Anode

Separator

Cathode

Positive Current Collector

Multimaterial setup

Electromagnetic properties definition

Open Circuit Voltage curve definition

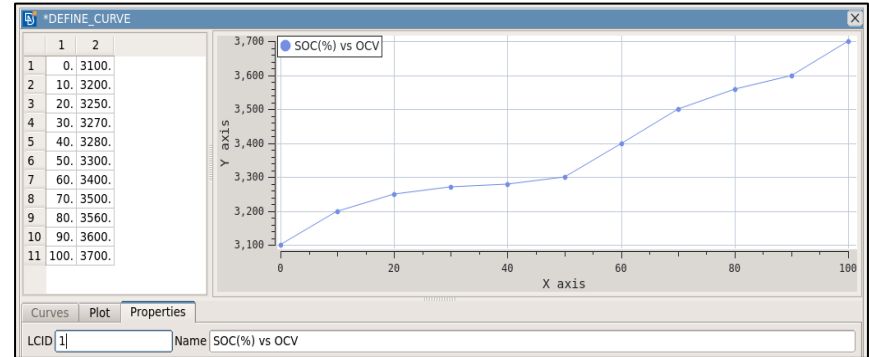

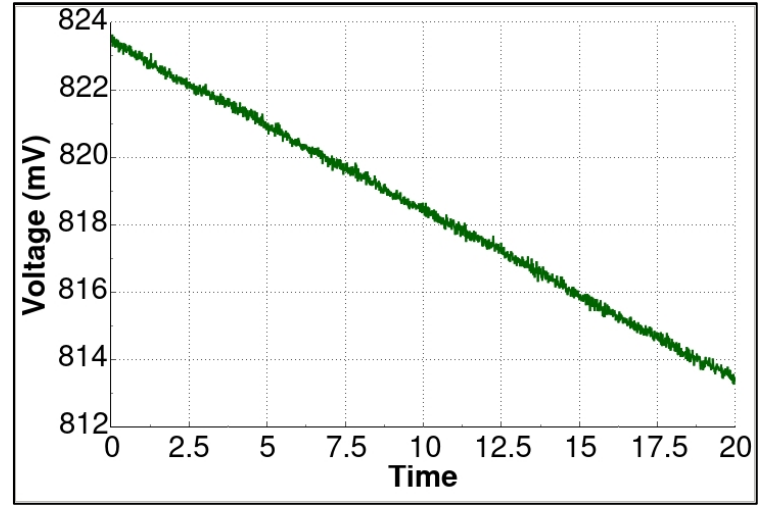
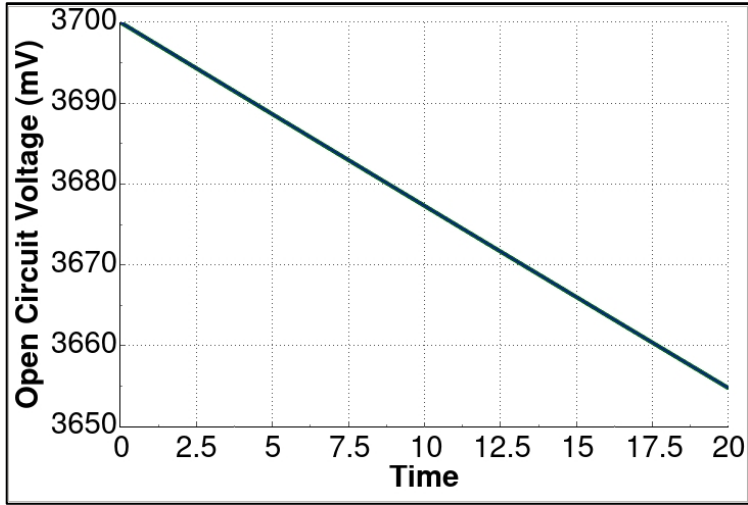

Open Circuit

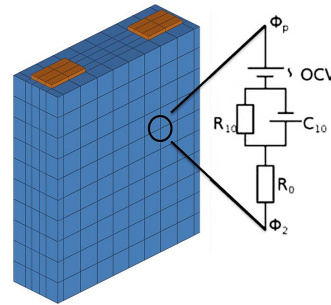

Closed Circuit



Distributed Randles

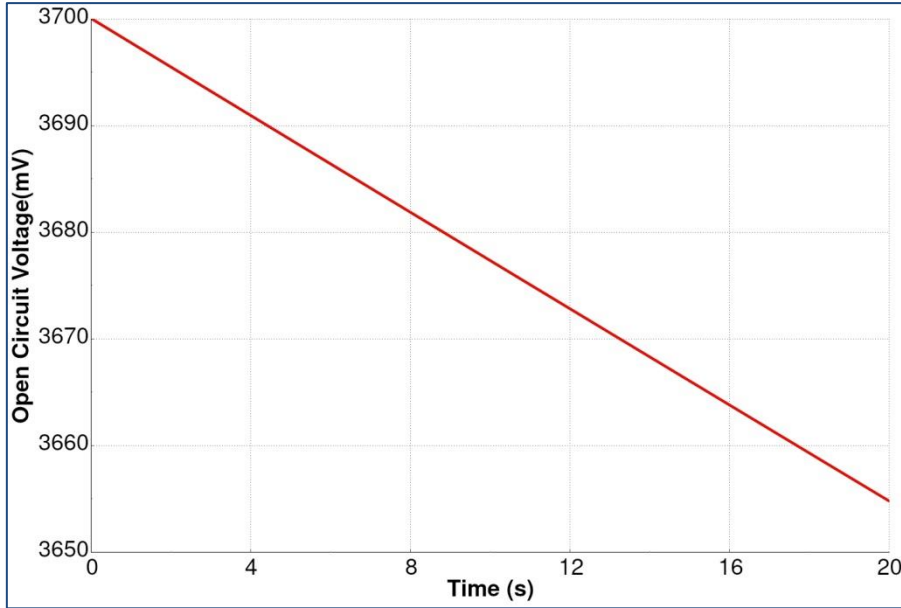

BatMac Randles

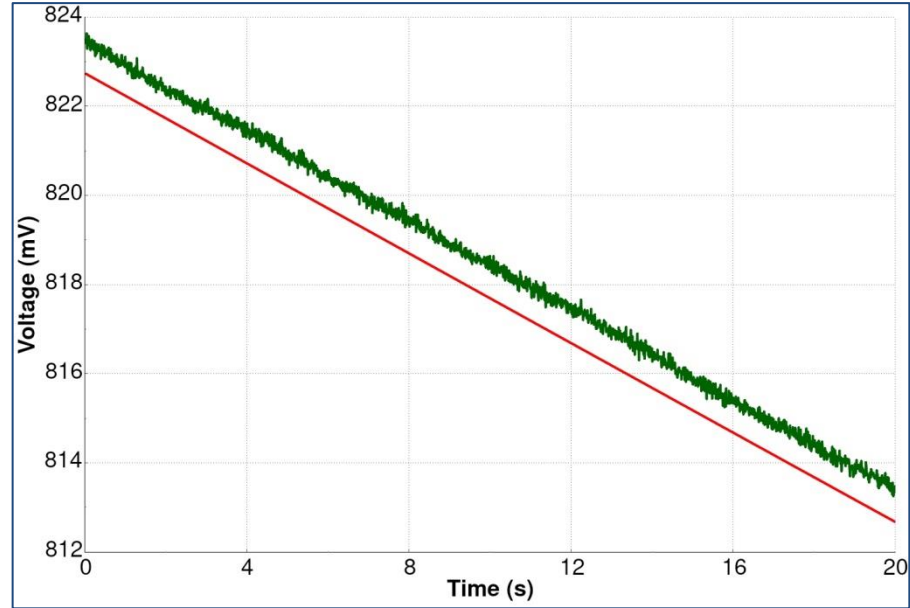

**Distributed Randles**

**BatMac Randles**

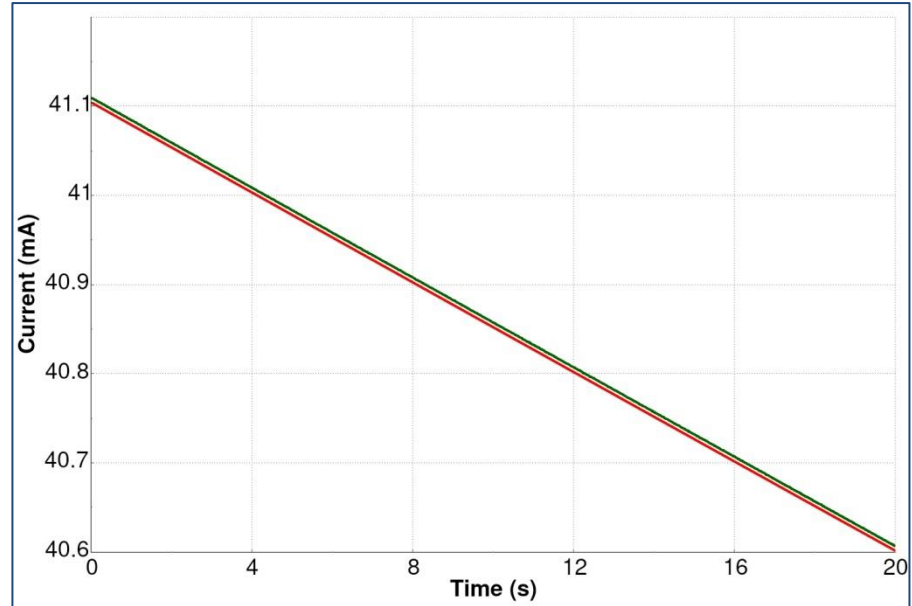
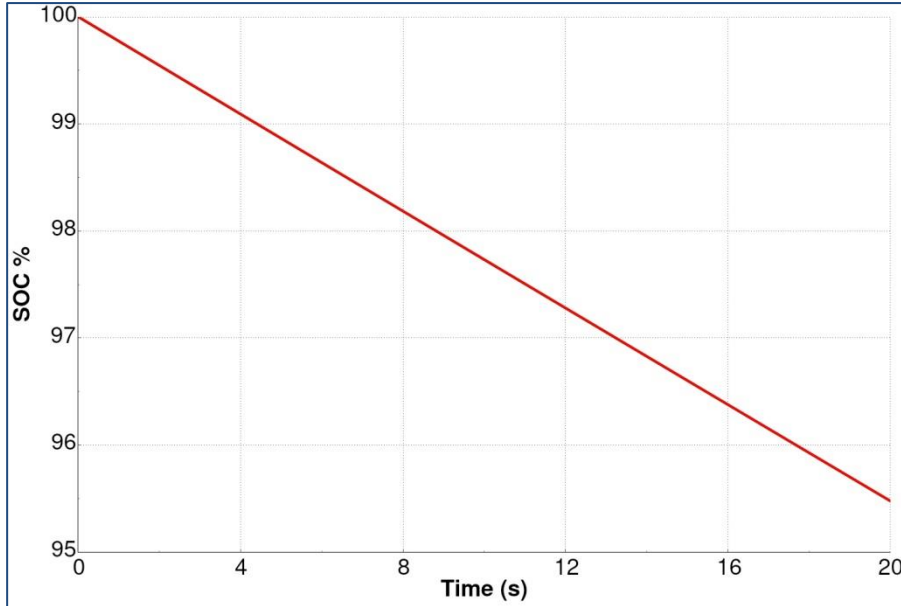

### Parallel Setup

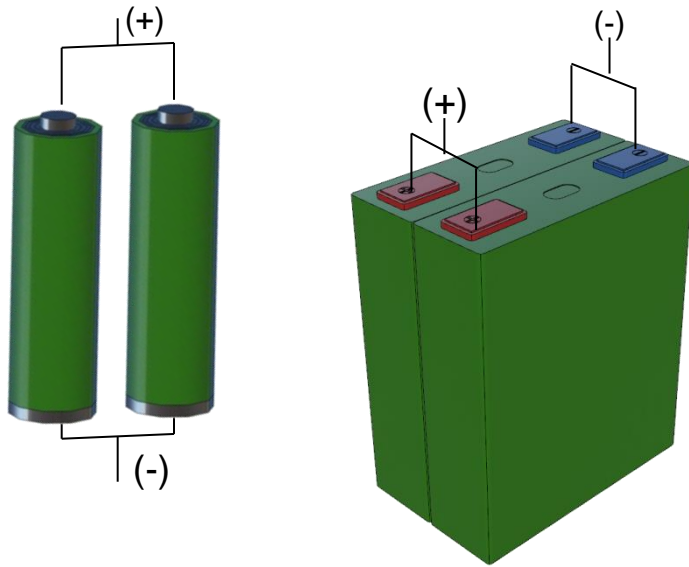

### Serial Setup

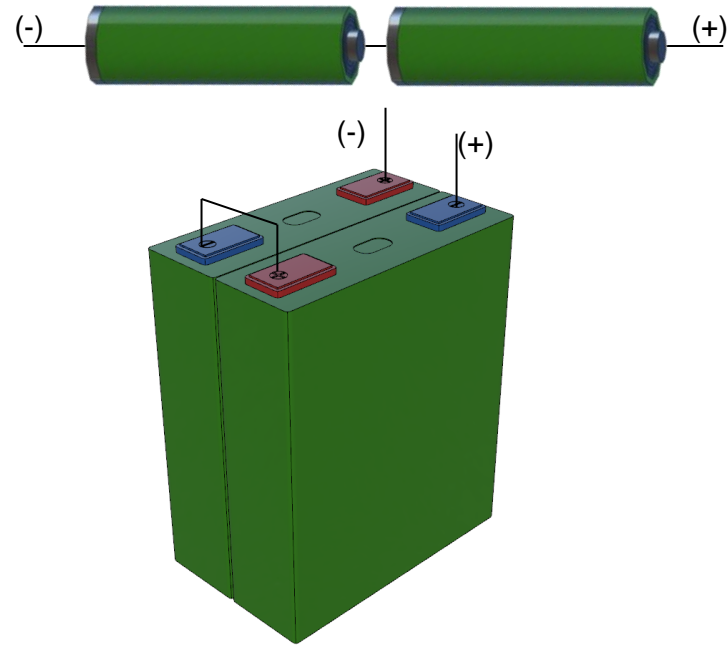



## 4 Batteries Connected in Parallel

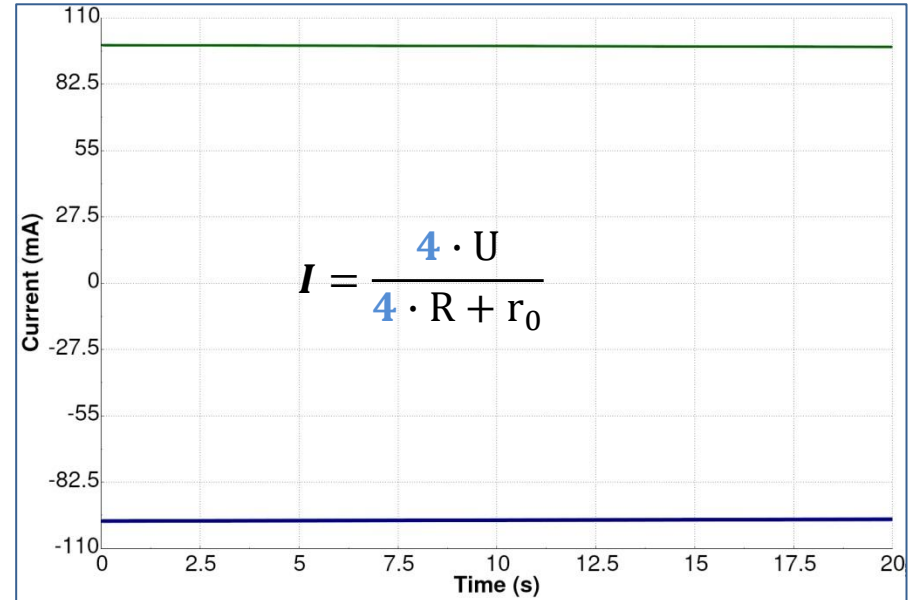
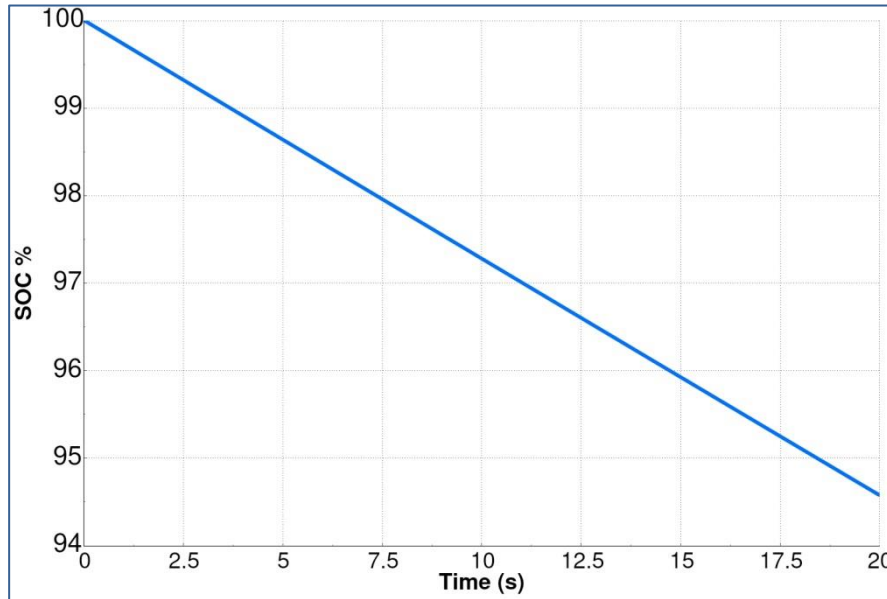

$$V = V_1 = V_2 = V_3 = V_4$$

## 4 Batteries Connected in Series

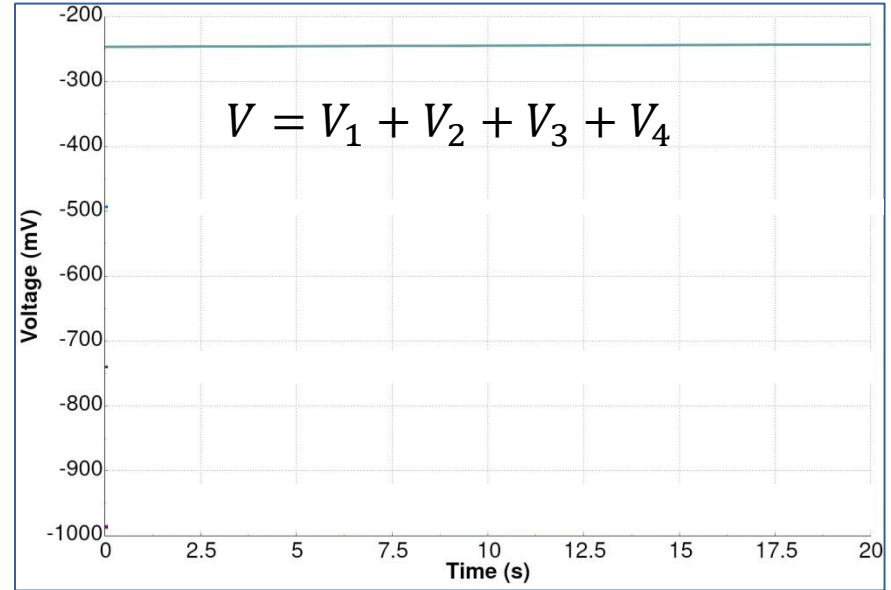
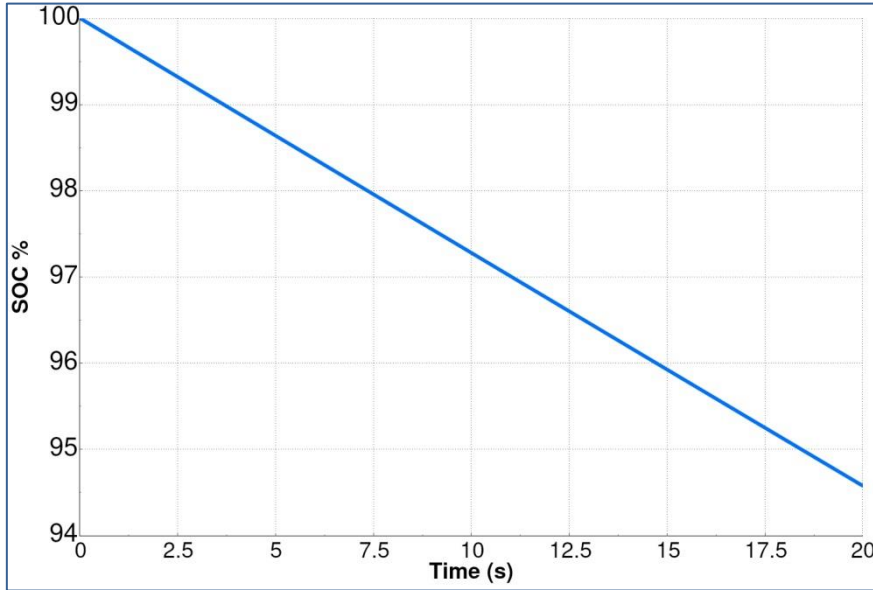

$$I = I_1 = I_2 = I_3 = I_4$$

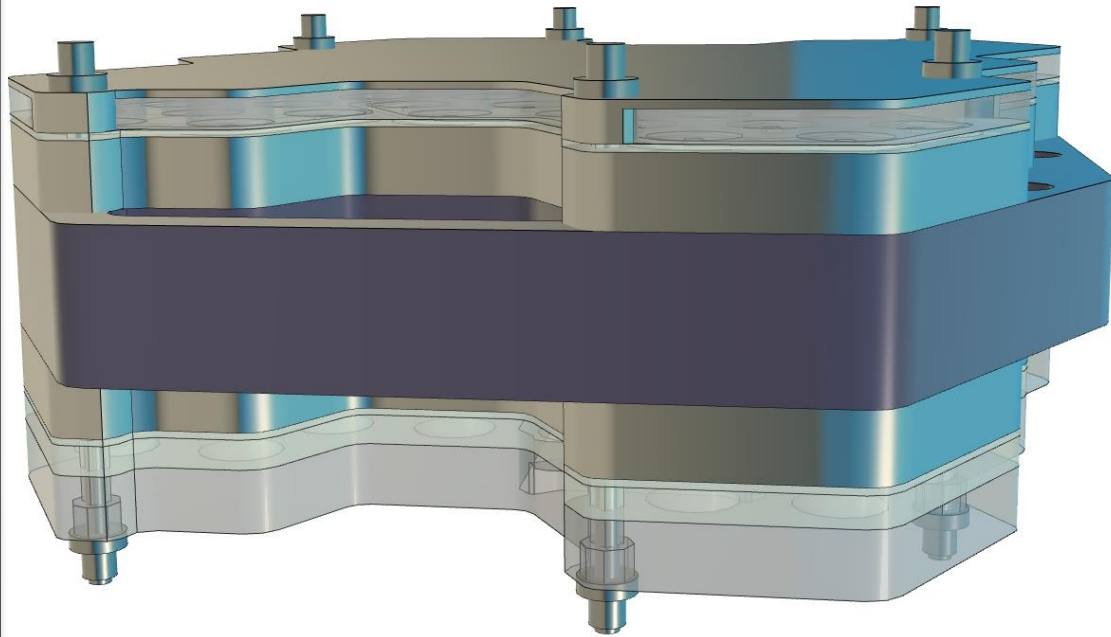

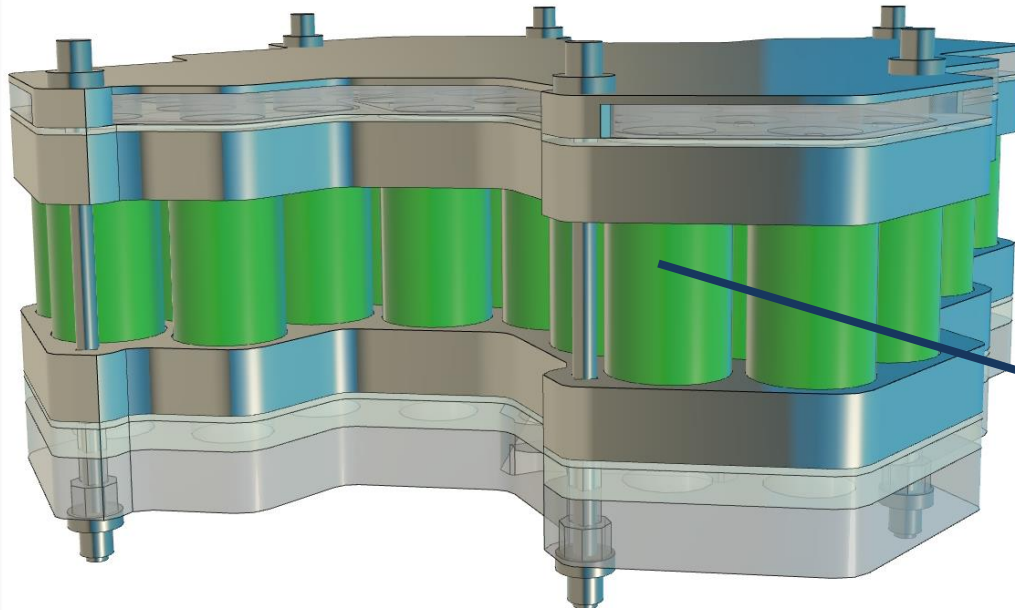

**Materials**

Stainless Steel 306

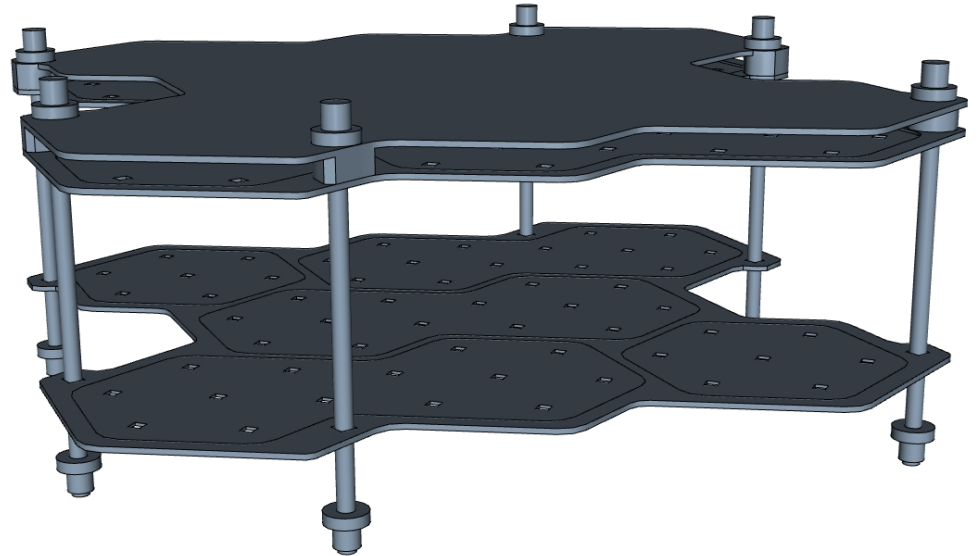

### Materials

Stainless Steel 306

Aluminum Alloy

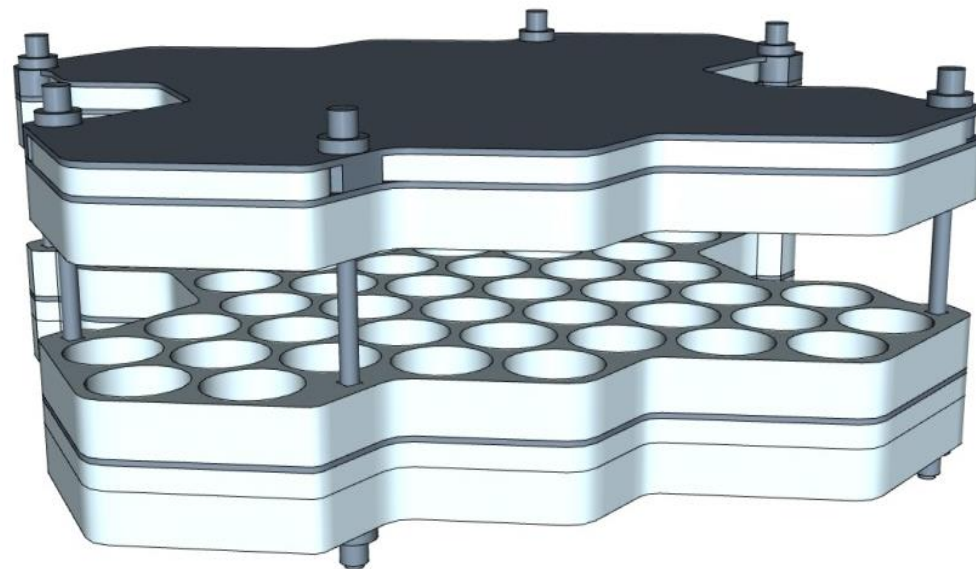

**Materials**

Stainless Steel 306

Aluminum Alloy

PVC Coating

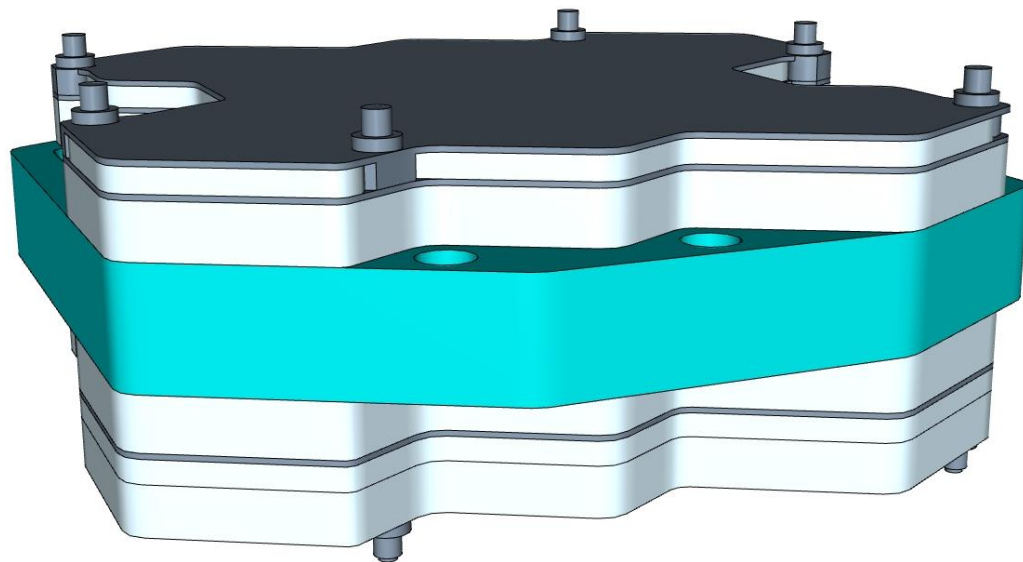

Materials
Stainless Steel 306
Aluminum Alloy
PVC Coating
Nickel-Plated Steel 9%

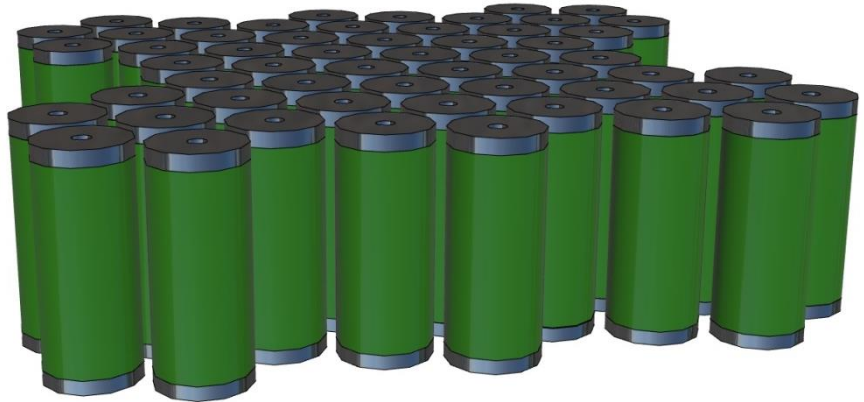



Internal Short Function

Compression Test

if Stress > Max Value

Internal Short R=0



Exothermal Reaction Function

Voltage Drop

if Voltage < Min Value

Exothermal Reaction



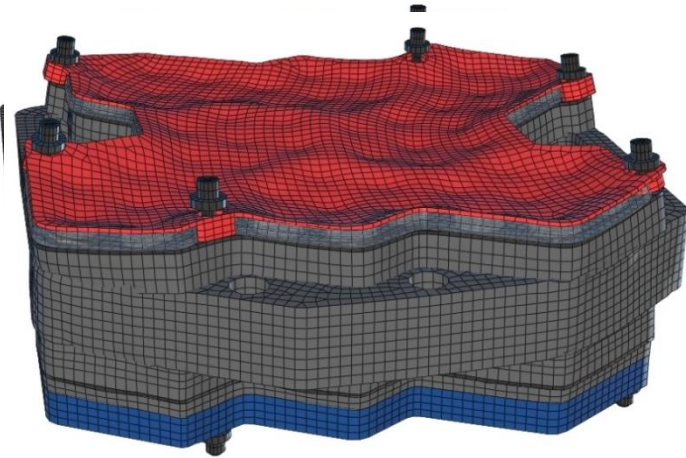

MODEL STATS		 <b>ANSA</b> <small>PRE PROCESSOR</small>	
Element Types		Hexa/Pentas	
Number of Elements		61139	
Simulation Time (sec)		2	
Solving Time (h)		72	
Number of CPUS		12	
Solver Type		Double Precision EM Solver	

Stresses, Von Mises

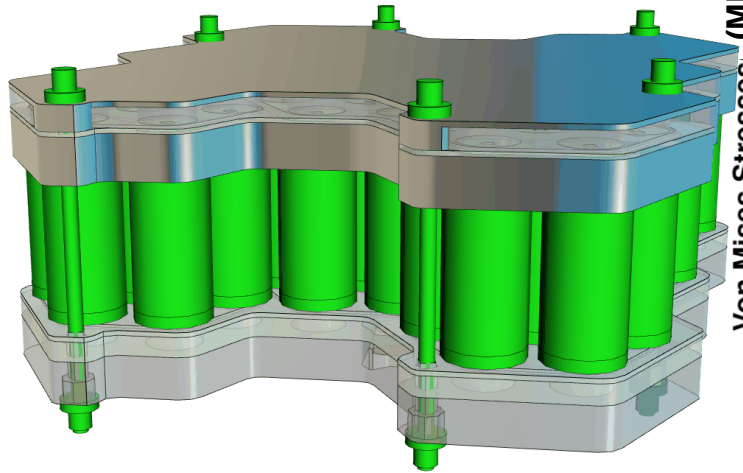
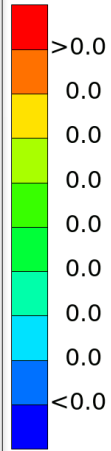

Von Mises Stresses (MPa)

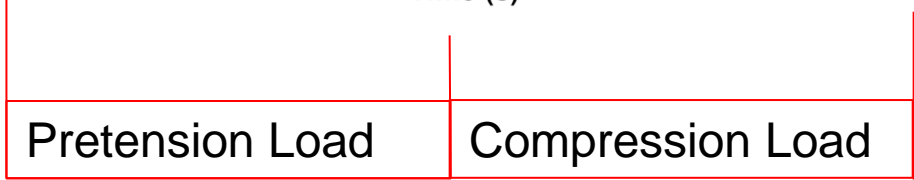
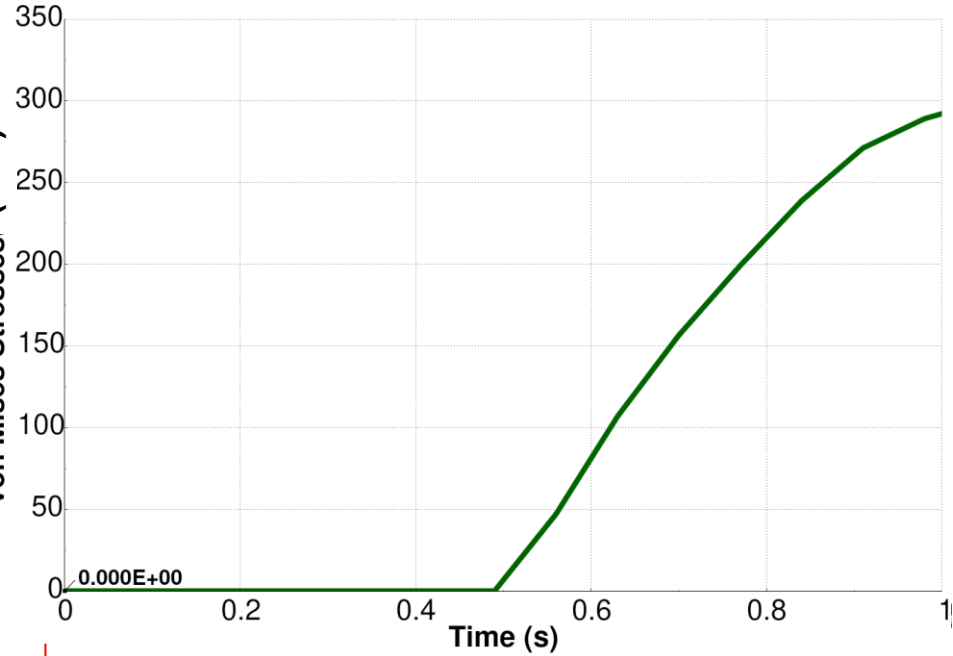

Displacements, Direction-Y

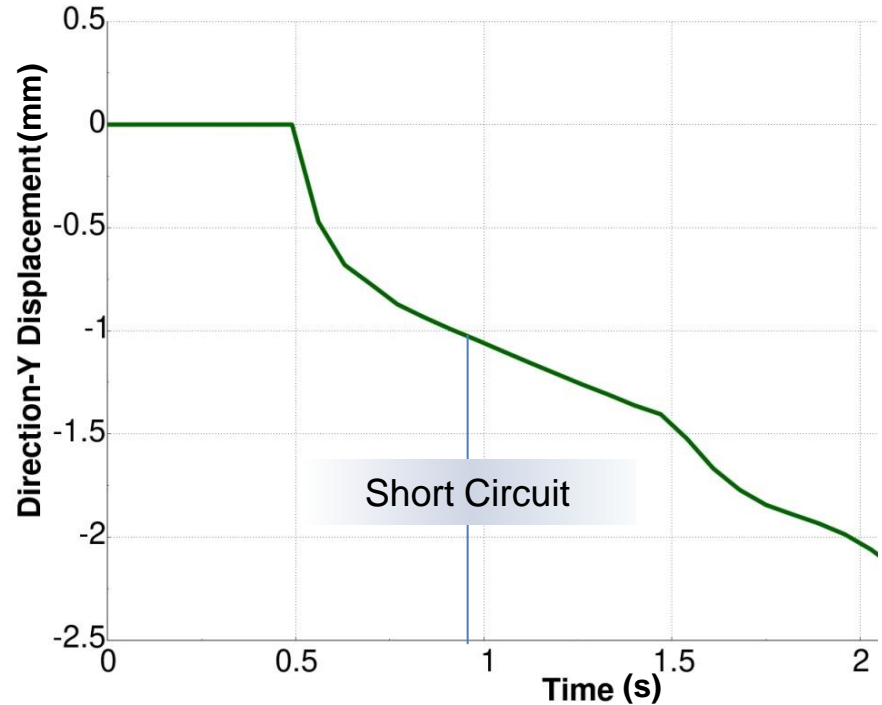
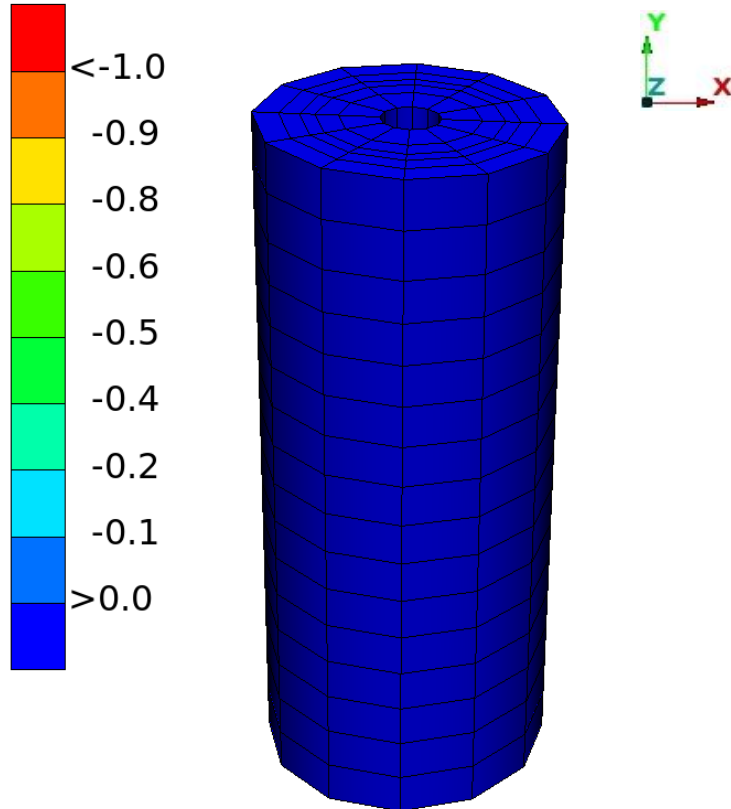

\*Chao Zhang et Al. 'A representative-sandwich model for simultaneously coupled mechanical-electrical-thermal simulation of a lithium-ion cell under quasi-static indentation tests'

Randles Circuit Resistance

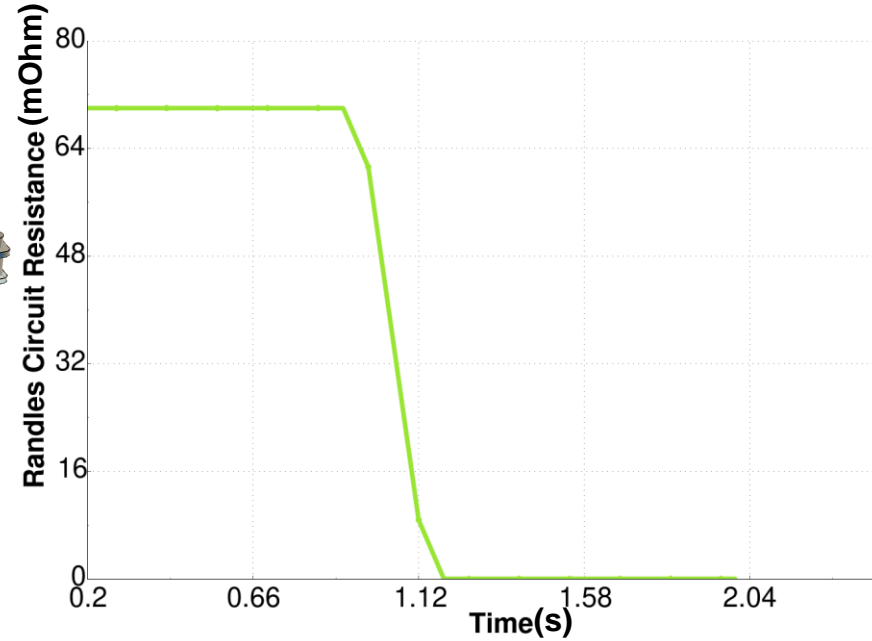
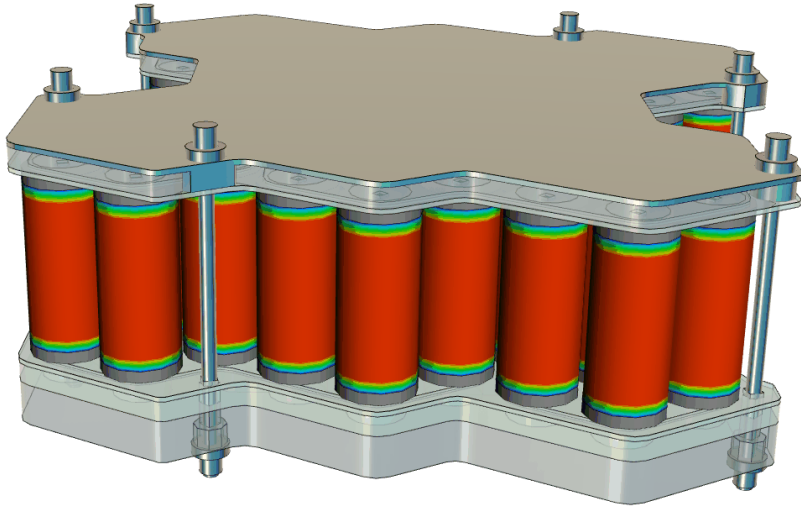
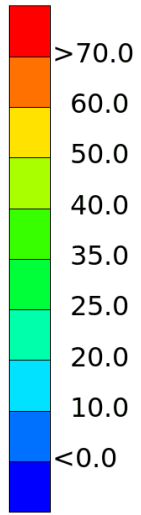

Temperature (Celcius)

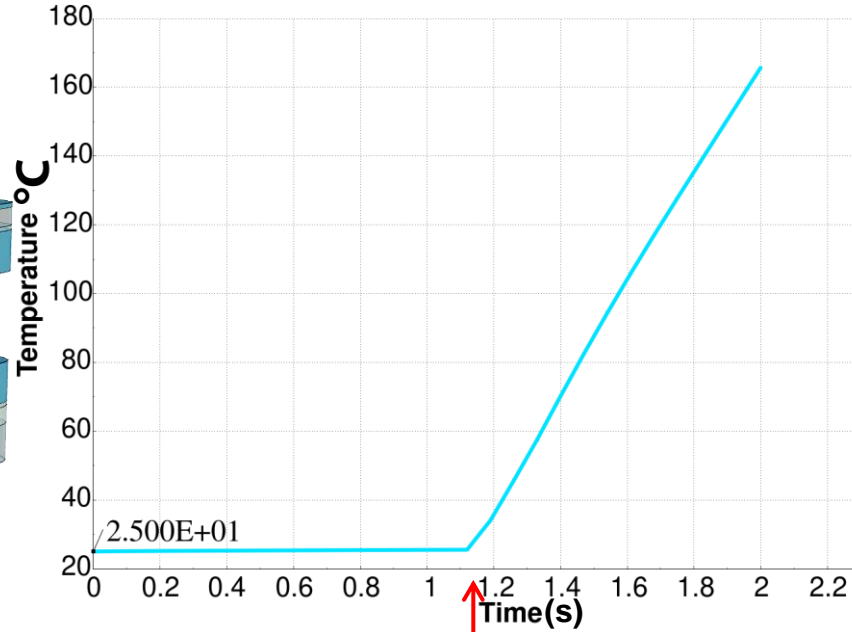
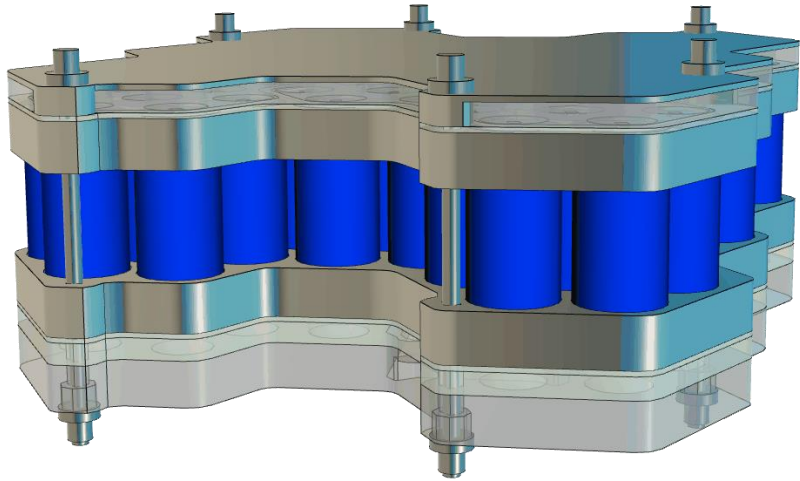
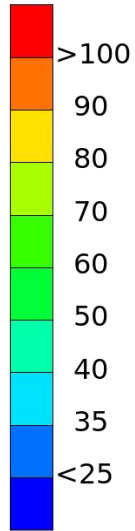

Exothermal Reaction Starting Point

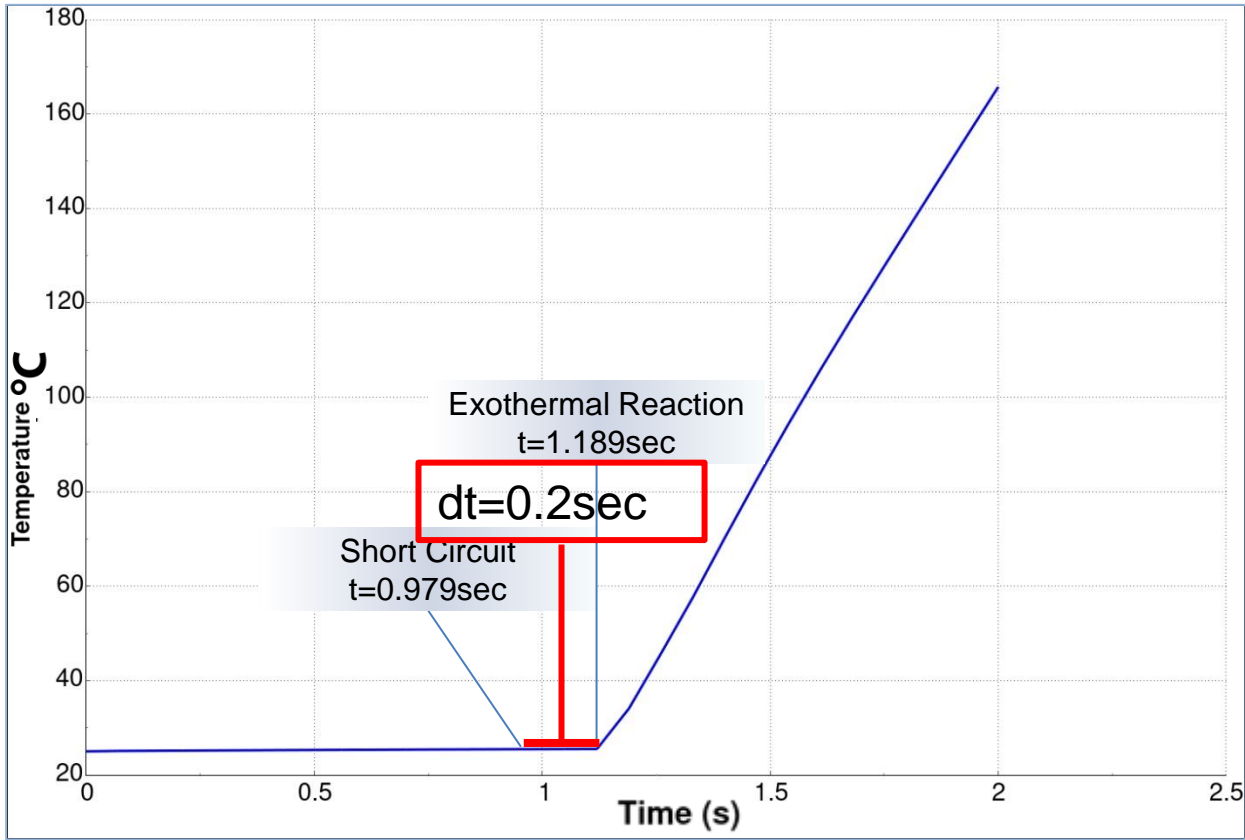

Rising electromagnetic simulation needs

Complete package to simulate batteries

Coupled simulations are possible

Support of wide range of post-processing results





Stay connected