

## Volkswagen Osnabrück FATXML: Increased Data Consistency through the CAE Process Chain

The neutral standard format for conveying product data

Virtual-product development in the Automotive Industry demands high-performance and robust engineering simulation processes. As the automation level of these processes increases, the engineering simulation models become more complex, the number of their variants multiply, and a modular approach is being taken in product definition, the appropriate documentation of the virtual-product evolution status is required.

For the comprehensive documentation and for the valid simulation-based decision making, it is imperative that product data and meta-data are maintained and available throughout the engineering simulation process, from CAE pre-processing until post-processing.

The freely available neutral FATXML format, developed by the FAT-AK27 workgroup, enables data and meta-data availability, consistency, and traceability. BETA CAE Systems supports this format and adopts its concepts in its simulation software suite.

"The integrated support of the FATXML format and concepts in BETA CAE Systems software, allowed for a seamless adoption of the standard into the Volkswagen Osnabrück processes. The related software features allow us to save time, while providing an online experience in accessing model documentation."

Thomas Deiters  
Volkswagen Osnabrück GmbH

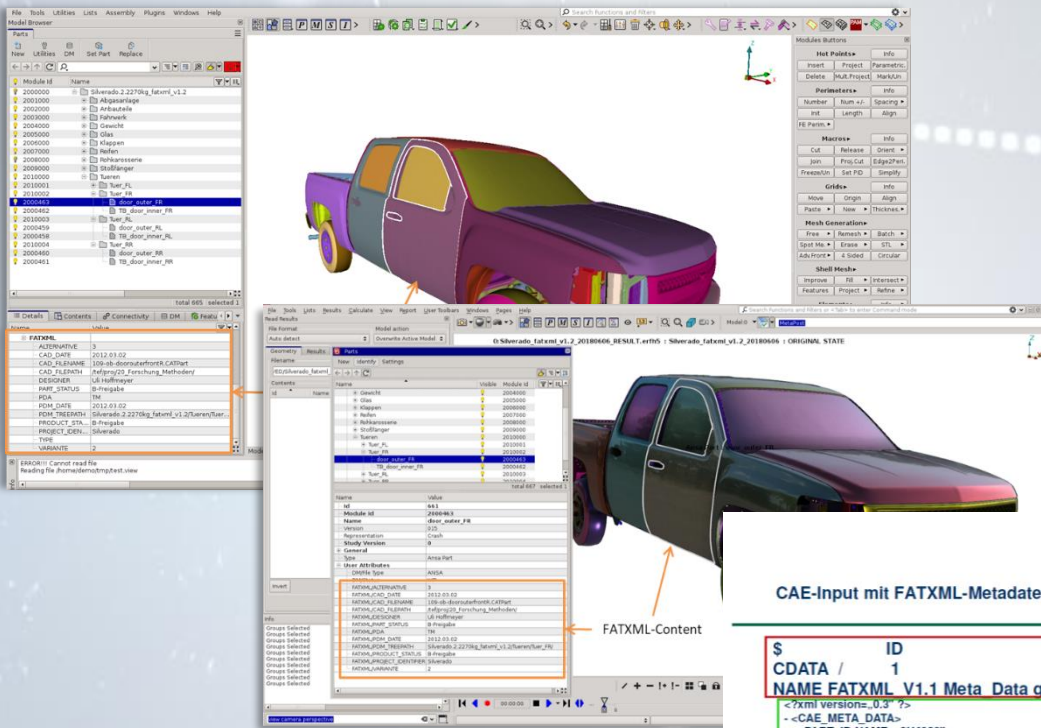

### CAE-Input mit FATXML-Metadaten für PAM-CRASH

```

$ ID PAM-CARSH-Daten
CDATA / 1
NAME FATXML V1.1 Meta Data generated by ANSA Vers. 13.1, Date: 21.09.2010
<?xml version="0.3" ?>
<-CAE_META_DATA>
<-PART_ID NAME="3H4920">
<-PDM_DATA>
<PART_SUB_ID=1><PART_SUB_ID>
<PART_NAME=Tuerrinnenblech><PART_NAME>
<PART_VERSION=B14><PART_VERSION>
<VEHICLE_STATUS=K-Freeze><VEHICLE_STATUS>
<PDM_TREEPATH=1><PDM_TREEPATH>
<PART_TYP=NEU><PART_TYP>
<-PDD_MATERIAL>
<MATERIAL ID="1111"><Z40><MATERIAL>
<MATERIAL ID="1112"><Z50><MATERIAL>
<PDD_MATERIAL>
<-PDD_THICKNESS>
<THICKNESS ID="1111">1.0<THICKNESS>
<THICKNESS ID="1112">1.2<THICKNESS>
<-PDD_THICKNESS>
<-PDM_DATA>
<PART_ID>
<-CAE_META_DATA>
END_CDATA
  
```

FAT-XML-Meta Daten

Mit der CDATA-Karte können ab PAM-CRASH V2009 Meta-Informationen übertragen und ab V2010 in den Ergebnisfile geschrieben werden.

## Challenge

The objective was the establishment of a public, neutral, and standardized format for the conveyance of product data and meta-data throughout the CAE process chain, for the comprehensive product status documentation and the valid simulation-based decision making.

Such data include information about parts hierarchy structure, the original CAD material and thickness selected etc. These should be accessible throughout the entire CAE process, as part of the model definition and its documentation.

Moreover, the information content should be extended, beyond the usual solver keyword content. Thus, a tighter integration with the Product Development Management (PDM) systems data is pursued.

The approach to taken should facilitate the modularity and the flexibility in the CAE processes, while the medium of conveying these meta-data should perform in a widely accepted, standardized manner, common to its core among different simulation codes.

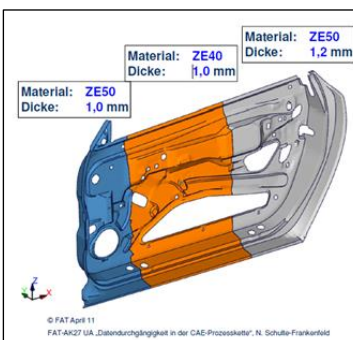

Example:

- CAD Part ID: 3H4920
- CAD Part Name: TB\_Tuerrinnenblech
- PDM\_Treepath: /FAHRZEUG/TUER\_LINKS/ZSB\_TUERINNENBLECH/
- Part consists of 3 Distinct thickness regions
- Constructed by: Jimi Hendrix, Tel: 299889 am 21.09.2010 erstellt
- Maturity Level: Series

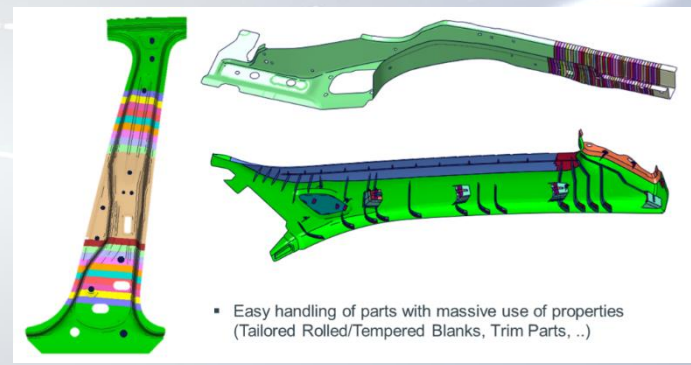
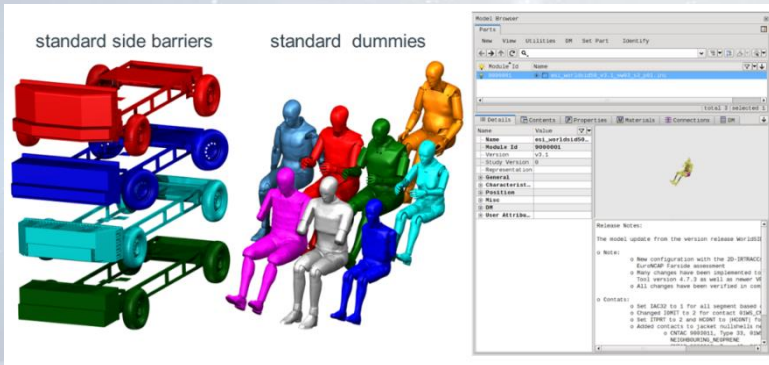

## Approach

The “Working Group, AK27 data-continuity in the CAE-process chain” was established by the FAT. This Working Group consisted of Automotive OEM’s and engineering software ISVs. The main objective of the Group was to conceive, document, standardise, and promote a format that would make available the product-defining data throughout CAE-processes. This was accomplished with the standardisation of the FATXML format.

By exploiting this format, the product information originating in the PDM system can be imported and interpreted by the pre-processor and implanted in the solver input files. The solver codes should be able to make the FATXML content available in their results file, so that next, the post-processor can access the data through it.

Basic capabilities enabled include:

- Model navigation across a PDM-tree, automatically generated from FATXML data.
- Comparison between PDM basic data and CAE model.
- Selection of model differences between PDM basic data and CAE model.
- Ability to extend the core meta-data by the addition of OEM-specific meta-data to the standard.

## Results

The FATXML format is a xml-based standard that has been published and made available by The German Association of the Automotive Industry (VDA).

Notably, it includes specific implementations for: Abaqus, LS-DYNA, NASTRAN, OptiStruct, Radioss, PAM-CRASH and PERMAS.

With the appropriate implementation of FATXML, simulation engineers can have easy access to meta-data during simulation results post-processing and evaluation. This enables unique capabilities to the decision-making stage, without adding effort or cost to the existing simulation processes.

BETA CAE Systems proactively contributed to the definition of the FATXML format specifications and effectively adopted the format and its concepts in ANSA pre-processor and META post-processor, for all the available solvers implementations.

For more about BETA CAE Systems, visit [www.beta-cae.com](http://www.beta-cae.com)

FATXML-Format Version V1.2\_R4, 18. Feb 2022.  
[https://www.vda.de/vda/de/aktuelles/publikationen/publication/fatxml-format-version-v1.2\\_r4](https://www.vda.de/vda/de/aktuelles/publikationen/publication/fatxml-format-version-v1.2_r4)